



BEACH COMMUNITY DEVELOPMENT DISTRICT

Advanced Meeting Package

Regular Meeting

*Monday
January 15, 2024
6:00 p.m.*

*Location:
12788 Meritage Blvd.,
Jacksonville, FL 32246*

*Note: The Advanced Meeting Package is a working document and thus all materials are considered **DRAFTS** prior to presentation and Board acceptance, approval, or adoption.*

Beach

Community Development District

250 International Parkway, Suite 208
Lake Mary, FL 32746
321-263-0132

Board of Supervisors
Beach Community Development District

Dear Board Members:

The Regular Meeting of the Board of Supervisors of the Beach Community Development District is scheduled for **Monday, January 15, 2024, at 6:00 p.m.** at the **12788 Meritage Blvd., Jacksonville, FL 32246**

An advanced copy of the agenda for the meeting is attached along with associated documentation for your review and consideration. Any additional support material will be distributed at the meeting.

Should you have any questions regarding the agenda, please contact me at (321) 263-0132 X-193 or dmcinnes@vestapropertyservices.com. We look forward to seeing you at the meeting.

Sincerely,

David McInnes

David McInnes
District Manager

Cc: Attorney
Engineer
District Records

Beach Community Development District

Meeting Date: Monday, January 15, 2024 Call-in Number: +1 (929) 205-6099
Time: 6:00 PM Meeting ID: 705 571 4830#
Location: 12788 Meritage Blvd., Jacksonville, FL 32246 (Listen Only)

Agenda

- I. Roll Call**
- II. Pledge of Allegiance**
- III. Presentation**
 - A. Ed Edminton, Trustee – Follow-up from 12/18/23 Regular Board Meeting
- IV. Audience Comments – (limited to 3 minutes per individual for agenda items)**
- V. Presentation of Proof of Publication(s)** [Exhibit 1](#)
- VI. Vendor Reports**
 - A. Vesta Property Services
 - 1. Lifestyle Management Report – *To Be Distributed*
 - a. Request for Reimbursement of CPR Certifications from American Red Cross [Exhibit 2](#)
 - 2. Field Management Report [Exhibit 3](#)
 - B. Advanced Security Specialist
 - C. Tree Amigos
 - D. Presentation of LLS Tax Solutions Arbitrage Report – Period Ending 11/03/23 [Exhibit 4](#)
- VII. Consent Agenda**
 - A. Consideration for Approval – The Minutes of the Board of Supervisors Regular Meeting Held on December 18, 2023 – *To Be Distributed*
 - B. Consideration for Acceptance – The December 2023 Unaudited Financial Statements – *To Be Distributed*
- VIII. Business Items**
 - A. Considerations of Landscape Lighting on Tamaya Blvd. Proposal(s) – *To Be Distributed*
 - B. Consideration of Irrigation Upgrade Proposal Options – Tamaya Hall [Exhibit 5](#)
 - C. Consideration of Pool Landscape Lighting Proposal Options [Exhibit 6](#)
 - D. Consideration of Improvements at Intersection on Meritage Blvd. Proposal Options [Exhibit 7](#)
 - E. Consideration of **Resolution 2024-06**, Amending FY23 Budget – *To Be Distributed*

IX. Discussion Topics

A. Showing ID at Guard House, Resident

X. Staff Reports

A. District Counsel

- 1. Draft Demand Letter Regarding Trees Planted on CDD ROW
– *Under Separate Cover*

B. District Engineer

C. District Manager

- 1. Resident(s) Subject Disciplinary Action
- 2. Complaint & Incident Management Tracker
- 3. Action Item Report
- 4. Meeting Matrix
- 5. Workshop Date, Time, & Topics
- 6. Presentation of Draft FY25 Budget

[Exhibit 8](#)

[Exhibit 9](#)

XI. Closed Session - In accordance with Sections 119.071(3)(a) and 281.301, *Florida Statutes*, a portion of the Regular Meeting may be closed to the public, as it relates to the District’s security system plan. The closed session is scheduled to begin at 7:30 p.m. but may begin at any time during the Regular Meeting and is expected to last approximately sixty (60) minutes but may end earlier than expected or may extend longer. When the security system plan agenda item is discussed, the public will be asked to leave. The public will be notified that they may return upon completion of the discussion regarding the security system plan.

XII. Supervisors’ Requests

XIII. Audience Comments (*limited to 3 minutes per individual for non-agenda items*)

XIV. Action Items Summary

XV. Meeting Matrix Summary

XVI. Next Meeting Quorum Check: February 19, 6:00 PM

Elena Korsakova	<input type="checkbox"/> IN PERSON	<input type="checkbox"/> REMOTE	<input type="checkbox"/> NO
Chance Wedderburn	<input type="checkbox"/> IN PERSON	<input type="checkbox"/> REMOTE	<input type="checkbox"/> NO
Sheila S. Papelbon	<input type="checkbox"/> IN PERSON	<input type="checkbox"/> REMOTE	<input type="checkbox"/> NO
Matt Calderaro	<input type="checkbox"/> IN PERSON	<input type="checkbox"/> REMOTE	<input type="checkbox"/> NO
Robert Renn	<input type="checkbox"/> IN PERSON	<input type="checkbox"/> REMOTE	<input type="checkbox"/> NO

XVII. Adjournment

EXHIBIT 1

**BEACH COMMUNITY
DEVELOPMENT DISTRICT
NOTICE OF BOARD OF
SUPERVISORS
REGULAR MEETING**

Notice is hereby given that a regular meeting of the Board of Supervisors of the Beach Community Development District (the "**District**") will be held on Monday, January 15, 2024, at 6:00 p.m. at 12788 Meritage Blvd. Jacksonville, FL 32246. The purpose of the meeting is to discuss any topics presented to the board for consideration.

In accordance with Sections 119.071(3)(a) and 281.301, Florida Statutes, a portion of the Board Meeting may be closed to the public, as it relates to the District's security system plan. The closed session is scheduled to begin at 8:00 p.m. but may begin at any time during the meeting and is expected to last approximately 30 minutes but may end earlier than expected or may extend longer. When the security system plan agenda item is discussed, the public will be asked to leave. The public will be notified that they may return upon completion of the discussion regarding the security system plan.

Copies of the agenda may be obtained from the District Manager, Vesta District Services, 250 International Parkway, Suite 208, Lake Mary, Florida 32746, Telephone (321) 263-0132, Ext. 193.

The meeting is open to the public and will be conducted in accordance with the provisions of Florida law for community development districts. The meeting may be continued in progress without additional notice to a date, time, and place to be specified on the record at the meeting. There may be occasions when Staff and/or Supervisors may participate by speaker telephone.

Pursuant to provisions of the Americans with Disabilities Act, any person requiring special accommodations to participate in the meeting is asked to advise the District Manager's office at least forty-eight (48) hours before the meeting by contacting the District Manager at (321) 263-0132, Ext. 193. If you are hearing or speech impaired, please contact the Florida Relay Service at 711, for assistance in contacting the District Manager's office.

A person who decides to appeal any decision made at the meeting, with respect to any matter considered at the meeting, is advised that a record of the proceedings is needed and that accordingly, the person may need to ensure that a verbatim record of the proceedings is made, including the testimony and evidence upon which the appeal is to be based.

**Beach Community
Development District**

David McInnes,
District Manager
(321) 263-0132, Ext. 193

Jan. 4 00 (24-00103D)

EXHIBIT 2



**American
Red Cross**

ORDER CONFIRMATION
O-0016056960

Vesta Property Services
245 Riverside Avenue Suite 250
Jacksonville, FL 32202, US
EMAIL: apcorporate@vestapropertyservices.com

ORDER DATE: Jan 04, 2024
STATUS: Shipped

American Express
Charge Amount: \$304.00

ORDER DETAILS

Item ID	Item	Class ID	Class Date	Order Quantity	UOM	Price	Extension
AP-HSSSFA415-r.21	Adult and Pediatric First Aid/CPR/AED	CLS-04529543	2024-01-04 -2024-01-04	8	Each	\$38.00	\$304.00
TOTAL							\$304.00

STUDENT ROSTER

Class ID	Student Name	Email	Phone	Evaluation Results	QR Code
CLS-04529543	Pat Kovacs	patkovacs2@yahoo.com	4076947868	Successful	01DPDES
CLS-04529543	Tammy Durham	jeepgirl720@yahoo.com	9044459422	Successful	01DPDEU
CLS-04529543	Dana Harden	dharden@vestapropertyservices.com	9045715848	Successful	01DPDF0
CLS-04529543	Joselyn McCreary	josmccreary@gmail.com	9045879768	Successful	01DPDF2
CLS-04529543	Caile	caileharden06@gmail.com	9048689914	Successful	01DPDF4

	Harden				
CLS-04529543	Kaden Fernandes	fernandeskadenjames@gmail.com	3059057856	Successful	01DPDF6
CLS-04529543	Ronald Zastrocky	rzastrocky@vestapropertyservices.com	9045773075	Successful	01DPDF8
CLS-04529543	Oliver Ingram	oingram@vestapropertyservices.com	9043346703	Successful	01DPDFA

Thank you for your order. If you paid for this order with a credit card this document serves as your receipt. If you selected Invoice as your payment method, your organization will receive an Invoice to pay for this order.

Please visit the Red Cross Learning Center (www.redcrosslearningcenter.org) to view information about your order and account. Instructors can view student certificates and rosters and access digital materials in the Red Cross Learning Center.

For questions related to training:

Live chat with a representative: www.redcross.org/take-a-class

Email: support@redcrosstraining.org

Phone: 1-800-REDCROSS (1-800-733-2767)

Select the option for Training & Certification

For questions related to Invoicing/billing:

Email: billing@redcross.org

Phone: 1-888-284-0607

HOURS OF OPERATION (Eastern Time)

- M-F: 7:30am-10pm
- Sat: 7:30am-8pm
- Sun: Closed

EXHIBIT 3



TAMAYA
BETWEEN THE CITY AND THE SEA

**20
24**

FIELD OPERATIONS REPORT

JANUARY



Prepared By :

Ron Zastrocky

Presented To :

Beach CDD Supervisors

 904.577.3075

 rzastrocky@vestapropertyservices.com





Tree Amigos

Outdoor Services

December 2023

Fungus/Pest/Fertilizer: All turf at Beach CDD was sprayed with herbicide to help attack winter weeds, and promote grass growth

Maintenance: Regular monthly maintenance was serviced to all turf areas inside Beach CDD. All ornamental grasses were trimmed down on Meritage Blvd to promote new growth for the spring. Ornamental grass trimming has been started in pocket parks and will continue throughout the winter season.

Annuals: Weekly winter annual maintenance was serviced to all annual beds, including dead heading flowers and weed pulling.

Irrigation Report: Irrigation heads were serviced as needed. The irrigation has been turned off in pocket parks in attempt to save water usage while the grass is in a dormant stage

Notes: Moving forward into January we will continue tree trimming around amenity center and pocket parks. The roses will be cut back and fertilized to promote a healthy flush out in the spring.



Spray Report

Customer: Tree Amigos

Property: Tamaya

Date: 12/11/23

Area treated +/- 14 acres.

Total Gallons used: 1600

Product:

Princep @ 64oz per acre

2, 4-D @ 8oz per acre

MSM @ .3oz per acre

Daconil @ 80oz per acre (IPM)

Target for this application was to improve the overall health, color, and growth of the turf. Insecticides and post emergent herbicides were applied for turf destroying insects and weeds, such as sedges and broadleaf weeds. Should start to see some results in 10-21 days



Event Name: Water Management - Zone 2 Thank you for Work Order Number: 1845282 your business! Completed Date: 1/4/2024 Target Pests (if applicable): Service Notes & Observations Treated Ponds 12- 22 for algae. Please allow up to two weeks for full results Environmental Conditions Weather: Sunny Temperature: 60.21 Wind Direction: North Wind Speed: 1 Humidity: 55.0000 Treated for Algae

Treated and inspected ponds 1 - 11. Algae was very minimal but, required light treatments. Overall ponds are in excellent condition. Thanks Environmental Conditions Weather: Sunny Temperature: 60.31 Wind Direction: North-East Wind Speed: 3.5 Humidity: 55.0000 Treated for Algae

General Maintenance Report

- Removed many PVC markers.
- Installed decals on Guardhouse doors.



- Put resident gate arm back on after it was hit.
- Put guest gate arm back on after it fell off, will need to check for tightness.
- Put desk and chair together for check-in area.
- Installed camera program on computer for check-in area.
- Zip tied many wind screens at tennis courts.
- Cleaned life rings at pool.
- Turned off irrigation clocks off at pocket parks.
- New fountain installed at Amenity center pond.



General Maintenance Report

·Tree cut down in wet lands by Ostia Cir.



·Diagnosed interactive playground with a factory rep and engineer.
Parts will be given to District at N/C.

Should you have any questions regarding this report or if you have a maintenance related request please contact me at the information below.



904.577.3075



rzastrocky@vestapropertyservices.com

EXHIBIT 4



LLS Tax Solutions Inc.
2172 W. Nine Mile Rd.
#352
Pensacola, FL 32534
Telephone: 850-754-0311
Email: liscott@llstax.com

December 14, 2023

Mr. David McInnes
Beach Community Development District
c/o Vesta District Services
250 International Parkway, Suite 208
Lake Mary, Florida 32746

**Beach Community Development District
\$10,960,000 Capital Improvement Revenue Bonds, Series 2013A and
\$7,115,000 Capital Improvement Revenue Bonds, Series 2013B
("Bonds")**

Dear Mr. McInnes:

Attached you will find our arbitrage rebate report for the above-referenced Bonds for the fifth-year period ended November 3, 2023 ("Computation Period"). This report indicates that there is no cumulative rebatable arbitrage liability as of November 3, 2023.

All proceeds of the Bonds are spent, but the Series 2013A portion of the Bonds is still outstanding as of November 3, 2023, and thus remains subject to arbitrage compliance.

The next annual arbitrage rebate calculation date is November 3, 2024. If you have any questions or comments, please do not hesitate to contact me at (850) 754-0311 or by email at liscott@llstax.com.

Sincerely,

Linda L. Scott

Linda L. Scott, CPA

cc: Ms. Caroline Cowart, BNY Mellon

Beach Community Development District

*Beach Community Development District
\$10,960,000 Capital Improvement Revenue Bonds, Series
2013A and \$7,115,000 Capital Improvement Revenue Bonds,
Series 2013B*

For the period ended November 3, 2023



LLS Tax Solutions Inc.
2172 W. Nine Mile Rd.
#352
Pensacola, FL 32534
Telephone: 850-754-0311
Email: liscott@llstax.com

December 14, 2023

Beach Community Development District
c/o Vesta District Services
250 International Parkway, Suite 208
Lake Mary, Florida 32746

Re: Beach Community Development District \$10,960,000 Capital Improvement Revenue Bonds, Series 2013A and \$7,115,000 Capital Improvement Revenue Bonds, Series 2013B (“Bonds”)

Beach Community Development District (“Client”) has requested that we prepare certain computations related to the above-described Bonds for the period ended November 3, 2023 (“Computation Period”). The scope of our engagement consisted of the preparation of computations to determine the Rebatale Arbitrage for the Bonds for the Computation Period as described in Section 148(f) of the Internal Revenue Code of 1986, as amended (“Code”), and this report is not to be used for any other purpose.

In order to prepare these computations, we were provided by the Client with and have relied upon certain closing documents for the Bonds and investment earnings information on the proceeds of the Bonds during the Computation Period. The attached schedule is based upon the aforementioned information provided to us. The assumptions and computational methods we used in the preparation of the schedule are described in the Summary of Notes, Assumptions, Definitions and Source Information. A brief description of the schedule is also attached.

The results of our computations indicate a negative Cumulative Rebatale Arbitrage of \$(1,266,589.42) at November 3, 2023. As such, no amount must be on deposit in the Rebate Fund.

As specified in the Form 8038G, the calculations have been performed based upon a Bond Yield of 6.9863%. Accordingly, we have not recomputed the Bond Yield.

The scope of our engagement was limited to the preparation of a mathematically accurate Rebatale Arbitrage for the Bonds for the Computation Period based on the information provided to us. The Rebatale Arbitrage has been determined as described in the Code, and regulations promulgated thereunder (“Regulations”), as applicable to the Bonds and in effect on the date of this report. We have no obligation to update this report because of events occurring, or information coming to our attention, subsequent to the date of this report.

LLS Tax Solutions Inc.

SUMMARY OF NOTES, ASSUMPTIONS, DEFINITIONS, SOURCE INFORMATION, AND DESCRIPTION OF SCHEDULE

Beach Community Development District

December 14, 2023

\$10,960,000 Capital Improvement Revenue Bonds, Series 2013A and

\$7,115,000 Capital Improvement Revenue Bonds, Series 2013B

For the period ended November 3, 2023

NOTES AND ASSUMPTIONS

1. The issue date of the Bonds is November 4, 2013.
2. The end of the first Bond Year for the Bonds is November 3, 2018.
3. Computations of yield are based upon a 30-day month, a 360-day year and semiannual compounding.
4. We have assumed that the only funds and accounts relating to the Bonds that are subject to rebate under section 148(f) of the Code are shown in the attached schedule.
5. For investment cash flow purposes, all payments and receipts are assumed to be paid or received, respectively, as shown in the attached schedule. In determining the Rebatable Arbitrage for the Bonds, we have relied on information provided by you without independent verification, and we can therefore express no opinion as to the completeness or suitability of such information for such purposes. In addition, we have undertaken no responsibility to review the tax-exempt status of interest on the Bonds.
6. We have assumed that the purchase and sale prices of all investments as represented to us are at fair market value, exclusive of brokerage commissions, administrative expenses, or similar expenses, and representative of arms' length transactions that did not artificially reduce the Rebatable Arbitrage for the Bonds, and that no "prohibited payments" occurred and no "imputed receipts" are required with respect to the Bonds.
7. Ninety percent (90%) of the Rebatable Arbitrage as of the next "computation date" ("Next Computation Date") is due to the United States Treasury not later than 60 days thereafter ("Next Payment Date"). (An issuer may select any date as a computation date, as long as the first computation date is not later than five years after the issue date, and each subsequent computation date is no more than five years after the previous computation date.) No other payment of rebate is required prior to the Next Payment Date. The Rebatable Arbitrage as of the Next Computation Date will not be the Rebatable Arbitrage reflected herein but will be based on future computations that will include the period ending on the Next Computation Date. If all of the Bonds are retired prior to what would have been the Next Computation Date, one hundred percent (100%) of the unpaid Rebatable Arbitrage computed as of the date of retirement will be due to the United States Treasury not later than 60 days thereafter.
8. For purposes of determining what constitutes an "issue" under section 148(f) of the Code, we have assumed that the Bonds constitute a single issue and are not required to be aggregated with any other bonds.

SUMMARY OF NOTES, ASSUMPTIONS, DEFINITIONS, SOURCE INFORMATION, AND DESCRIPTION OF SCHEDULE

Beach Community Development District

December 14, 2023

\$10,960,000 Capital Improvement Revenue Bonds, Series 2013A and

\$7,115,000 Capital Improvement Revenue Bonds, Series 2013B

For the period ended November 3, 2023

NOTES AND ASSUMPTIONS (cont'd)

9. The accrual basis of accounting has been used to calculate earnings on investments. Earnings accrued but not received at the last day of the Computation Period are treated as though received on that day. For investments purchased at a premium or a discount (if any), amortization or accretion is included in the earnings accrued at the last day of the Computation Period. Such amortization or accretion is computed in such a manner as to result in a constant rate of return for such investment. This is equivalent to the “present value” method of valuation that is described in the Regulations.
10. No provision has been made in this report for any debt service fund. Under section 148(f)(4)(A) of the Code, a “bona fide debt service fund” for public purpose bonds issued after November 10, 1988, is not subject to rebate if the average maturity of the issue of bonds is at least five years and the rates of interest on the bonds are fixed at the issue date. It appears and has been assumed that the debt service fund allocable to the Bonds qualifies as a bona fide debt service fund, and that this provision applies to the Bonds.
11. The proceeds of the Series 2013 Bonds were used for the following purposes: (a) to finance a portion of the cost of acquiring, constructing and equipping certain assessable improvements in the District (the “Project”); (b) to fund deposits to the Series 2013A Reserve Account and Series 2013B Reserve Account in the amounts of the Series 2013A Reserve Account Requirement and Series 2013B Reserve Account Requirement, respectively; (c) to pay capitalized interest on the Series 2013 Bonds through November 1, 2014; and (d) to pay the costs and expenses incurred in connection with the issuance of the Series 2013 Bonds.
12. All proceeds of the Bonds are spent. The Series 2013B portion of the Bonds matured on May 1, 2017, but the Series 2013A portion of the Bonds is still outstanding as of November 3, 2023, and thus remains subject to arbitrage compliance.
13. Article 1 amendment to First Supplement dated October 1, 2020, states that the amount on deposit in the Series 2013A Reserve Account shall no longer apply. The Series 2013A Reserve Account Requirement shall mean Zero Dollars.

SUMMARY OF NOTES, ASSUMPTIONS, DEFINITIONS, SOURCE INFORMATION, AND DESCRIPTION OF SCHEDULE

Beach Community Development District

December 14, 2023

\$10,960,000 Capital Improvement Revenue Bonds, Series 2013A and

\$7,115,000 Capital Improvement Revenue Bonds, Series 2013B

For the period ended November 3, 2023

DEFINITIONS

1. *Bond Year*: Each one-year period that ends on the day selected by the Client. The first and last Bond Years may be shorter periods.
2. *Bond Yield*: The yield that, when used in computing the present value (at the issue date of the Bonds) of all scheduled payments of principal and interest to be paid over the life of the Bonds, produces an amount equal to the Issue Price.
3. *Allowable Earnings*: The amount that would have been earned if all nonpurpose investments were invested at a rate equal to the Bond Yield, which amount is determined under a future value method described in the Regulations.
4. *Computation Date Credit*: A credit allowed by the Regulations as a reduction to the Rebtable Arbitrage on certain prescribed dates.
5. *Rebtable Arbitrage*: The excess of actual earnings over Allowable Earnings and Computation Date Credits.
6. *Issue Price*: Generally, the initial offering price at which a substantial portion of the Bonds is sold to the public. For this purpose, 10% is a substantial portion.

SUMMARY OF NOTES, ASSUMPTIONS, DEFINITIONS, SOURCE INFORMATION, AND DESCRIPTION OF SCHEDULE

Beach Community Development District

December 14, 2023

\$10,960,000 Capital Improvement Revenue Bonds, Series 2013A and

\$7,115,000 Capital Improvement Revenue Bonds, Series 2013B

For the period ended November 3, 2023

SOURCE INFORMATION

Bonds

Source

Closing Date

Form 8038G

Bond Yield

Form 8038G

Investments

Source

Principal and Interest Receipt Amounts
and Dates

Trust Statements

Investment Dates and Purchase Prices

Trust Statements

SUMMARY OF NOTES, ASSUMPTIONS, DEFINITIONS, SOURCE INFORMATION, AND DESCRIPTION OF SCHEDULE

Beach Community Development District

December 14, 2023

\$10,960,000 Capital Improvement Revenue Bonds, Series 2013A and

\$7,115,000 Capital Improvement Revenue Bonds, Series 2013B

For the period ended November 3, 2023

DESCRIPTION OF SCHEDULE

SCHEDULE 1 - REBATABLE ARBITRAGE CALCULATION

Schedule 1 sets forth the amount of interest receipts and gains/losses on sales of investments and the calculation of the Rebatable Arbitrage.

BEACH COMMUNITY DEVELOPMENT DISTRICT
 \$10,960,000 CAPITAL IMPROVEMENT REVENUE BONDS, SERIES 2013A AND
 \$7,115,000 CAPITAL IMPROVEMENT REVENUE BONDS, SERIES 2013B

SCHEDULE 1 - REBATABLE ARBITRAGE CALCULATION

11 / 4 / 2013 ISSUE DATE
 11 / 4 / 2018 BEGINNING OF COMPUTATION PERIOD
 11 / 3 / 2023 COMPUTATION DATE

DATE	FUND/ACCOUNT	INVESTMENT VALUE AT COMPUTATION DATE	EARNINGS ON INVESTMENTS	OTHER DEPOSITS (WITHDRAWALS)	FUTURE VALUE AT BOND YIELD 6.9863%	ALLOWABLE EARNINGS
11 / 4 / 2018	BEGINNING BALANCE		0.00	434,291.07	612,088.35	177,797.28
11 / 4 / 2018	INTEREST ACCRUAL REVERSAL		(961.07)	0.00	0.00	0.00
11 / 15 / 2018	2013A RESERVE FUND		873.70	0.00	0.00	0.00
11 / 15 / 2018	2013A RESERVE FUND		0.00	(873.70)	(1,228.81)	(355.11)
12 / 17 / 2018	2013A RESERVE FUND		0.00	(868.23)	(1,213.68)	(345.45)
12 / 31 / 2018	2013A RESERVE FUND		868.24	0.00	0.00	0.00
1 / 8 / 2019	2013A RESERVE FUND		693.32	0.00	0.00	0.00
1 / 9 / 2019	2013A RESERVE FUND		0.00	(693.32)	(965.12)	(271.80)
2 / 6 / 2019	2013A RESERVE FUND		984.56	0.00	0.00	0.00
2 / 8 / 2019	2013A RESERVE FUND		0.00	(984.56)	(1,362.98)	(378.42)
3 / 8 / 2019	2013A RESERVE FUND		885.23	0.00	0.00	0.00
3 / 11 / 2019	2013A RESERVE FUND		0.00	(885.23)	(1,217.78)	(332.55)
3 / 19 / 2019	2013A RESERVE FUND		0.00	(2,343.76)	(3,219.31)	(875.55)
4 / 8 / 2019	2013A RESERVE FUND		975.34	0.00	0.00	0.00
4 / 8 / 2019	2013A RESERVE FUND		0.00	(975.34)	(1,334.85)	(359.51)
4 / 15 / 2019	2013A RESERVE FUND		975.34	0.00	0.00	0.00
5 / 1 / 2019	2013A RESERVE FUND		0.38	0.00	0.00	0.00
5 / 7 / 2019	2013A RESERVE FUND		926.24	0.00	0.00	0.00
5 / 10 / 2019	2013A RESERVE FUND		0.00	(926.24)	(1,259.93)	(333.69)
5 / 16 / 2019	2013A RESERVE FUND		(975.34)	0.00	0.00	0.00
6 / 5 / 2019	2013A RESERVE FUND		945.47	0.00	0.00	0.00
6 / 5 / 2019	2013A RESERVE FUND		0.00	(945.47)	(1,279.97)	(334.50)
7 / 5 / 2019	2013A RESERVE FUND		903.79	0.00	0.00	0.00
7 / 9 / 2019	2013A RESERVE FUND		0.00	(903.79)	(1,215.64)	(311.85)
8 / 7 / 2019	2013A RESERVE FUND		922.78	0.00	0.00	0.00
8 / 12 / 2019	2013A RESERVE FUND		0.00	(922.78)	(1,233.39)	(310.61)
9 / 6 / 2019	2013A RESERVE FUND		1,030.50	0.00	0.00	0.00
9 / 6 / 2019	2013A RESERVE FUND		0.00	(1,030.50)	(1,371.08)	(340.58)
9 / 16 / 2019	2013A RESERVE FUND		0.00	(1,122.46)	(1,490.59)	(368.13)
9 / 16 / 2019	2013A RESERVE FUND		0.00	(0.42)	(0.56)	(0.14)
10 / 7 / 2019	2013A RESERVE FUND		1,014.41	0.00	0.00	0.00
10 / 8 / 2019	2013A RESERVE FUND		0.00	(1,014.41)	(1,341.46)	(327.05)

BEACH COMMUNITY DEVELOPMENT DISTRICT
 \$10,960,000 CAPITAL IMPROVEMENT REVENUE BONDS, SERIES 2013A AND
 \$7,115,000 CAPITAL IMPROVEMENT REVENUE BONDS, SERIES 2013B

SCHEDULE 1 - REBATABLE ARBITRAGE CALCULATION

11 / 4 / 2013 ISSUE DATE
 11 / 4 / 2018 BEGINNING OF COMPUTATION PERIOD
 11 / 3 / 2023 COMPUTATION DATE

DATE	FUND/ACCOUNT	INVESTMENT VALUE AT COMPUTATION DATE	EARNINGS ON INVESTMENTS	OTHER DEPOSITS (WITHDRAWALS)	FUTURE VALUE AT BOND YIELD 6.9863%	ALLOWABLE EARNINGS
11 / 5 / 2019	2013A RESERVE FUND		924.27	0.00	0.00	0.00
11 / 5 / 2019	2013A RESERVE FUND		0.00	(924.27)	(1,215.98)	(291.71)
12 / 4 / 2019	2013A RESERVE FUND		692.53	0.00	0.00	0.00
12 / 4 / 2019	2013A RESERVE FUND		0.00	(692.53)	(906.07)	(213.54)
1 / 9 / 2020	2013A RESERVE FUND		691.02	0.00	0.00	0.00
1 / 9 / 2020	2013A RESERVE FUND		0.00	(691.02)	(898.08)	(207.06)
2 / 6 / 2020	2013A RESERVE FUND		661.31	0.00	0.00	0.00
2 / 6 / 2020	2013A RESERVE FUND		0.00	(661.31)	(855.05)	(193.74)
3 / 6 / 2020	2013A RESERVE FUND		601.61	0.00	0.00	0.00
3 / 9 / 2020	2013A RESERVE FUND		0.00	(601.61)	(772.98)	(171.37)
3 / 17 / 2020	2013A RESERVE FUND		0.00	(8,343.75)	(10,704.18)	(2,360.43)
3 / 17 / 2020	2013A RESERVE FUND		0.00	8,343.75	10,704.18	2,360.43
3 / 17 / 2020	2013A RESERVE FUND		0.00	(8,343.75)	(10,704.18)	(2,360.43)
4 / 6 / 2020	2013A RESERVE FUND		492.31	0.00	0.00	0.00
4 / 6 / 2020	2013A RESERVE FUND		0.00	(492.31)	(629.30)	(136.99)
5 / 6 / 2020	2013A RESERVE FUND		329.43	0.00	0.00	0.00
5 / 7 / 2020	2013A RESERVE FUND		0.00	(329.43)	(418.61)	(89.18)
6 / 3 / 2020	2013A RESERVE FUND		276.22	0.00	0.00	0.00
6 / 3 / 2020	2013A RESERVE FUND		0.00	(276.22)	(349.26)	(73.04)
7 / 6 / 2020	2013A RESERVE FUND		196.69	0.00	0.00	0.00
7 / 7 / 2020	2013A RESERVE FUND		0.00	(196.69)	(247.09)	(50.40)
8 / 6 / 2020	2013A RESERVE FUND		155.29	0.00	0.00	0.00
8 / 6 / 2020	2013A RESERVE FUND		0.00	(155.29)	(194.01)	(38.72)
9 / 4 / 2020	2013A RESERVE FUND		139.49	0.00	0.00	0.00
9 / 10 / 2020	2013A RESERVE FUND		0.00	(139.49)	(173.14)	(33.65)
9 / 15 / 2020	2013A RESERVE FUND		0.00	(711.25)	(882.00)	(170.75)
10 / 5 / 2020	2013A RESERVE FUND		113.63	0.00	0.00	0.00
10 / 5 / 2020	2013A RESERVE FUND		0.00	(113.63)	(140.37)	(26.74)
10 / 27 / 2020	2013A RESERVE FUND		0.00	(416,558.75)	(512,439.91)	(95,881.16)
10 / 27 / 2020	2013A RESERVE FUND		0.00	(2,500.00)	(3,075.44)	(575.44)
10 / 27 / 2020	2013A RESERVE FUND		0.00	(1,250.00)	(1,537.72)	(287.72)
11 / 2 / 2020	2013A RESERVE FUND		0.07	0.00	0.00	0.00

BEACH COMMUNITY DEVELOPMENT DISTRICT
 \$10,960,000 CAPITAL IMPROVEMENT REVENUE BONDS, SERIES 2013A AND
 \$7,115,000 CAPITAL IMPROVEMENT REVENUE BONDS, SERIES 2013B

SCHEDULE 1 - REBATABLE ARBITRAGE CALCULATION

11 / 4 / 2013 ISSUE DATE
 11 / 4 / 2018 BEGINNING OF COMPUTATION PERIOD
 11 / 3 / 2023 COMPUTATION DATE

DATE	FUND/ACCOUNT	INVESTMENT VALUE AT COMPUTATION DATE	EARNINGS ON INVESTMENTS	OTHER DEPOSITS (WITHDRAWALS)	FUTURE VALUE AT BOND YIELD 6.9863%	ALLOWABLE EARNINGS
11 / 3 / 2020	2013A RESERVE FUND		0.00	(500.00)	(614.38)	(114.38)
11 / 4 / 2020	2013A RESERVE FUND		84.96	0.00	0.00	0.00
11 / 4 / 2020	2013A RESERVE FUND		0.00	(84.96)	(104.38)	(19.42)
11 / 19 / 2020	2013A RESERVE FUND		0.00	(0.07)	(0.09)	(0.02)
		<u>0.00</u>	<u>15,421.72</u>	<u>(15,421.72)</u>	<u>56,195.16</u>	<u>71,616.88</u>
11 / 4 / 2018	BEGINNING BALANCE		0.00	7.94	11.19	3.25
11 / 15 / 2018	2013A ACQUISITION/CONSTRUCTION ACCT #6001		0.02	0.00	0.00	0.00
12 / 12 / 2018	2013A ACQUISITION/CONSTRUCTION ACCT #6001		0.02	0.00	0.00	0.00
1 / 8 / 2019	2013A ACQUISITION/CONSTRUCTION ACCT #6001		0.01	0.00	0.00	0.00
2 / 6 / 2019	2013A ACQUISITION/CONSTRUCTION ACCT #6001		0.02	0.00	0.00	0.00
3 / 8 / 2019	2013A ACQUISITION/CONSTRUCTION ACCT #6001		0.02	0.00	0.00	0.00
4 / 8 / 2019	2013A ACQUISITION/CONSTRUCTION ACCT #6001		0.02	0.00	0.00	0.00
4 / 15 / 2019	2013A ACQUISITION/CONSTRUCTION ACCT #6001		0.02	0.00	0.00	0.00
5 / 7 / 2019	2013A ACQUISITION/CONSTRUCTION ACCT #6001		0.02	0.00	0.00	0.00
5 / 16 / 2019	2013A ACQUISITION/CONSTRUCTION ACCT #6001		(0.02)	0.00	0.00	0.00
6 / 5 / 2019	2013A ACQUISITION/CONSTRUCTION ACCT #6001		0.02	0.00	0.00	0.00
7 / 5 / 2019	2013A ACQUISITION/CONSTRUCTION ACCT #6001		0.02	0.00	0.00	0.00
8 / 7 / 2019	2013A ACQUISITION/CONSTRUCTION ACCT #6001		0.02	0.00	0.00	0.00
9 / 6 / 2019	2013A ACQUISITION/CONSTRUCTION ACCT #6001		0.02	0.00	0.00	0.00
10 / 7 / 2019	2013A ACQUISITION/CONSTRUCTION ACCT #6001		0.02	0.00	0.00	0.00
11 / 5 / 2019	2013A ACQUISITION/CONSTRUCTION ACCT #6001		0.02	0.00	0.00	0.00
12 / 4 / 2019	2013A ACQUISITION/CONSTRUCTION ACCT #6001		0.01	0.00	0.00	0.00
1 / 9 / 2020	2013A ACQUISITION/CONSTRUCTION ACCT #6001		0.01	0.00	0.00	0.00
2 / 6 / 2020	2013A ACQUISITION/CONSTRUCTION ACCT #6001		0.01	0.00	0.00	0.00
3 / 6 / 2020	2013A ACQUISITION/CONSTRUCTION ACCT #6001		0.01	0.00	0.00	0.00
4 / 6 / 2020	2013A ACQUISITION/CONSTRUCTION ACCT #6001		0.01	0.00	0.00	0.00
5 / 6 / 2020	2013A ACQUISITION/CONSTRUCTION ACCT #6001		0.01	0.00	0.00	0.00
6 / 3 / 2020	2013A ACQUISITION/CONSTRUCTION ACCT #6001		0.01	0.00	0.00	0.00
10 / 27 / 2020	2013A ACQUISITION/CONSTRUCTION ACCT #6001		0.00	416,558.75	512,439.91	95,881.16
10 / 28 / 2020	2013A ACQUISITION/CONSTRUCTION ACCT #6001		0.00	(416,567.00)	(512,352.32)	(95,785.32)
11 / 2 / 2020	2013A ACQUISITION/CONSTRUCTION ACCT #6001		0.07	0.00	0.00	0.00
11 / 4 / 2020	2013A ACQUISITION/CONSTRUCTION ACCT #6001		0.08	0.00	0.00	0.00

BEACH COMMUNITY DEVELOPMENT DISTRICT
 \$10,960,000 CAPITAL IMPROVEMENT REVENUE BONDS, SERIES 2013A AND
 \$7,115,000 CAPITAL IMPROVEMENT REVENUE BONDS, SERIES 2013B

SCHEDULE 1 - REBATABLE ARBITRAGE CALCULATION

11 / 4 / 2013 ISSUE DATE
 11 / 4 / 2018 BEGINNING OF COMPUTATION PERIOD
 11 / 3 / 2023 COMPUTATION DATE

DATE	FUND/ACCOUNT	INVESTMENT VALUE AT COMPUTATION DATE	EARNINGS ON INVESTMENTS	OTHER DEPOSITS (WITHDRAWALS)	FUTURE VALUE AT BOND YIELD 6.9863%	ALLOWABLE EARNINGS
11 / 19 / 2020	2013A ACQUISITION/CONSTRUCTION ACCT #6001		0.00	0.07	0.09	0.02
12 / 8 / 2020	2013A ACQUISITION/CONSTRUCTION ACCT #6001		36.98	0.00	0.00	0.00
1 / 6 / 2021	2013A ACQUISITION/CONSTRUCTION ACCT #6001		0.01	0.00	0.00	0.00
2 / 4 / 2021	2013A ACQUISITION/CONSTRUCTION ACCT #6001		0.01	0.00	0.00	0.00
3 / 3 / 2021	2013A ACQUISITION/CONSTRUCTION ACCT #6001		0.01	0.00	0.00	0.00
4 / 5 / 2021	2013A ACQUISITION/CONSTRUCTION ACCT #6001		0.01	0.00	0.00	0.00
5 / 6 / 2021	2013A ACQUISITION/CONSTRUCTION ACCT #6001		0.02	0.00	0.00	0.00
8 / 4 / 2021	2013A ACQUISITION/CONSTRUCTION ACCT #6001		0.01	0.00	0.00	0.00
11 / 5 / 2021	2013A ACQUISITION/CONSTRUCTION ACCT #6001		0.00	(37.27)	(42.74)	(5.47)
11 / 5 / 2021	2013A ACQUISITION/CONSTRUCTION ACCT #6001		0.00	0.01	0.01	0.00
		<u>0.00</u>	<u>37.49</u>	<u>(37.49)</u>	<u>56.14</u>	<u>93.63</u>
11 / 5 / 2021	INITIAL DEPOSIT		0.00	1.00	1.15	0.15
3 / 17 / 2023	2013A ACQUISITION/CONSTRUCTION ACCT #1066		0.00	(1.00)	(1.04)	(0.04)
		<u>0.00</u>	<u>0.00</u>	<u>0.00</u>	<u>0.11</u>	<u>0.11</u>
		<u>0.00</u>	<u>15,459.21</u>	<u>(15,459.21)</u>	<u>56,251.41</u>	<u>71,710.62</u>
	ACTUAL EARNINGS		15,459.21			
	ALLOWABLE EARNINGS		<u>71,710.62</u>			
	REBATABLE ARBITRAGE		(56,251.41)			
	FUTURE VALUE OF 11/3/2018 CUMULATIVE REBATABLE ARBITRAGE		(1,199,936.38)			
	FUTURE VALUE OF 11/3/2019 COMPUTATION DATE CREDIT		(2,276.87)			
	FUTURE VALUE OF 11/3/2020 COMPUTATION DATE CREDIT		(2,162.63)			
	FUTURE VALUE OF 11/3/2021 COMPUTATION DATE CREDIT		(2,042.05)			
	FUTURE VALUE OF 11/3/2022 COMPUTATION DATE CREDIT		(1,960.08)			
	COMPUTATION DATE CREDIT		<u>(1,960.00)</u>			
	CUMULATIVE REBATABLE ARBITRAGE		<u>(1,266,589.42)</u>			

EXHIBIT 5



Quotation

Quote #: 201574

Date: 10/16/2023

Billed To: Vesta Property Service
200 Business Park Circle #101
St. Augustine FL 32095

Project: 32253
Beach CDD Enhancements
200 Business Park Circle #101

St. Augustine FL 32095

This quote is valid until: 11/15/2023

Description	Common Name	Quantity	Price	Ext Price
Install new wifi controller , flow meter, master valve and weather station @ Clubhouse				
(1) Hunter part number A2C-75DP		1.00	2,400.00	2,400.00
(1) Wifi module		1.00	450.00	450.00
(1) Solar Sync weather station		1.00	195.00	195.00
(1) Hunter 2 inch Flow meter		1.00	900.00	900.00
(1) Flow meter module		1.00	475.00	475.00
(1) Flow meter decoder		1.00	600.00	600.00
(1) 2 inch master valve with decoder		1.00	450.00	450.00
(2) valve boxes		1.00	125.00	125.00
Labor		1.00	1,800.00	1,800.00

Notes

Total: \$7,395.00

Approved: _____

Date: _____

5000-18 Highway 17 No. 235 Fleming Island, FL 32003 Office: (904) 778-1030 Fax: (904) 778-1045

Email: cryan@treeamigosoutdoor.com
website: www.TreeAmigosOutdoor.com

P R O P O S A L

Conserva Irrigation of NEFL
 51 Hudson Way
 Ste 6
 Ponte Vedra , FL 32081
 (904) 862-2211



nefl@conservairrigation.com

<https://www.conservairrigation.com/northeast-florida/>

Billing/Service Address

Ron Zastrocky
 Beach CDD
 12788 Meritage Blvd
 Jacksonville, FL 32246
 (904) 577-3075 (Mobile)
 rzastrocky@vestapropertyservices.com

Date	January 2, 2024
Total	\$5,608.00

This proposal expires on 5/6/2024

N O T E S

The attached proposal is for the upgrades to your existing system. This will provide a more efficient overall system and ensure water savings overtime. Please take your time to go over everything and feel free to reach out with any questions or concerns. Thank you for considering Conserva Irrigation and we look forward to hearing from you. Have a great day!

Item	Description	Qty	Rate	Amount
Commercial Services	Commercial repair, upgrades and or maintenance - 1st Hr	1	0.00	\$0.00
Misc	Hunter ACC2 Controller 75 Station Outdoor	1	2010.00	\$2,010.00

Hunter Wifi Module	Hunter ACC2 wifi module	1	324.00	\$324.00
Hunter Solar Sync	Hunter Solar Sync ET/Rain/Freeze Sensor	1	123.00	\$123.00
Misc	Hunter Flow-sync flow sensor (Tee Not included)	1	302.00	\$302.00
Misc	Hunter Receptacle Tee PVC 2 in.	1	114.00	\$114.00
Misc	Hunter ICD Sensor Decoder	1	600.00	\$600.00
2" Valve Replaced	Hunter Globe Valve ICV Glass filled Nylon 2 in w/flow control and filter sentry FIPT x FIPT	1	270.00	\$270.00
Misc	Hunter ICD Decoder 1 station	1	210.00	\$210.00
Standard Rectangle Valve Box	NDS Standard Valve Box Rectangle 14 in. x 19 in. x 12 in.H Black Box/Green Lid Overlapping ICV	1	65.00	\$65.00
Standard Rectangle Valve Box	NDS Standard Valve Box Rectangle 14 in. x 19 in. x 12 in.H Reclaimed	1	75.00	\$75.00
Misc	Hunter ACC2 3 channel flow expansion module	1	315.00	\$315.00
Labor	Hourly labor to install listed items	8	150.00	\$1,200.00
			Subtotal	\$5,608.00
			Tax	\$0.00
			Total	\$5,608.00

You must select a payment plan before accepting your proposal. Please choose one below:

Credit Card

Credit card info required for service. Once each visit has been completed your card will be charged for

Pay \$1,869.15 upfront followed by 1 payments of \$3,738.85.

Select Plan

T E R M S A N D C O N D I T I O N S

LIMITED WARRANTY STATEMENT: Conserva Irrigation (“Service Provider”) guarantees the quality of the work performed at the Client’s (“Client” or “Customer”) premises. This warranty is effective for products installed and services provided by the Service Provider. Service Provider warrants to the original end user customer of its products specified below that its products are free from defects in material and workmanship. Repaired parts or replacement products will be provided by the local Conserva Irrigation Franchisee on an exchange basis and will be either new or refurbished to be functionally equivalent to new. Purchaser must present acceptable proof of original ownership (such as original receipt or other documentation Conserva Irrigation Franchisee deems acceptable).

DURATION OF WARRANTY: One-Year Extendable Warranty. Conserva Irrigation warrants all parts installed by Service Provider for a period of One Year from the date of installation. This warranty may be extended up to Five Years on all parts installed by Service Provider by purchasing a seasonal service package each contiguous year offered by Conserva Irrigation. Service Provider does not warrant damaged caused by lightning and other “Acts of God”, root intrusion, power surges, freeze damage, rodent damage, and similar events. Damage or material failures due to abuse or negligence by customer or other contractors are not covered by any warranty.

SITE CONDITIONS: The estimate for work provided is under normal site conditions. If after the work is started Service Provider identifies abnormal site conditions (i.e. unfavorable soil conditions, organic or other debris, excessive root growth, etc.) not foreseen in the estimate, the Service Provider will stop work immediately and inform the Client of any changes in the estimate. If the Client does not agree to the new estimated price, the Client agrees to pay for all work performed prior to the work stoppage.

UTILITY MARKING: If needed, the Service Provider will contact the public utility locating company to have the public utilities marked in the designated work area. Any private utilities on the property, (i.e. septic system, drain/leach field, dog fence, private electric and gas lines, landscape lighting, etc.) are the responsibility of the Client. If the Client does not notify the Service Provider of these private utilities, the Service Provider assumes no responsibility for damage.

SERVICE DELAYS: Service Provider is not responsible or liable for delays in the commencement or completion of the Services that are a result of conditions beyond Service Provider’s control (including, for example, weather, strikes, or a supplier’s inability to provide materials.) If Client fails to make a scheduled payment, Service Provider may elect to postpone its performance of the

Services at its discretion after receipt of all amounts due and payable. Delays caused by such events do not constitute abandonment.

CANCELLATION POLICY: Client must contact the Service Provider no later than 24 hours prior to the confirmed appointment time to cancel the service. If Client cancels the appointment within 24 hours of the appointment or does not show, Service Provider reserves the right to charge a service fee.

DISPUTES: This Service Agreement is made and shall be construed under the laws of the State in which it is contracted. Except as set forth below, if any controversy or claim arises out of or relates to this Service Agreement, or breach thereof, and cannot be settled through direct discussions, the parties must first endeavor to settle the controversy or claim by mediation administered by the American Arbitration Association under its Construction Industry Mediation Rules, before resorting to Arbitration Rules, and judgment of the award rendered by the arbitrator may be entered in any court having jurisdiction thereof. The parties may agree to mediation and arbitration by the Better Business Bureau in lieu of the forgoing. It is further agreed that any efforts by the Service Provider to collect amounts due or any part thereof will not be subject to the mediation and arbitration provisions set forth above. Client will pay any collection expense, court costs, and reasonable attorney's fees which may be incurred in such collection efforts. Client hereby waives any and all rights client may have to a jury in any suit hereunder.

ELECTRONIC CHECK RECOVERY SYSTEM: The Service Provider uses a third party for recovery of returned checks. If Client chooses to pay for Client's purchase by check and Client's bank returns the check, Client gives the Service Provider and its affiliates permission, in advance, to electronically debit Client's checking account for the check amount plus a return fee of the maximum amount allowed by this State.

PAYMENT: If the Client fails to fulfill their payment obligations under this Service Agreement the Service Provider has the right to charge interest from the payment due date to the date of payment at the lesser of 18% per annum or the maximum amount allowable under applicable law. The Service Provider also has the right to request a deposit when applicable.

NO WAIVER OF RIGHTS: Service Provider's failure to exercise a right or remedy or Service Provider's acceptance of a partial or delinquent payment, will not operate as a waiver of any of Service Provider's rights, or Client's obligations, under this Service Agreement and will not constitute a waiver of Service Provider's right to declare an immediate or a subsequent default of this Service Agreement.

ENTIRE AGREEMENT: This Service Agreement contains the entire understanding and agreement between the parties with respect to the Services and supersedes all prior or contemporaneous written and oral agreements and understandings with respect to the subject matter hereof. No oral or promises or agreements are a part of this service agreement.

Click [here](#) if you no longer wish to receive notifications or related information about this proposal.

EXHIBIT 6



Quote

Lamp Sales Unlimited, Inc.

4580 St. Augustine Road
 Jacksonville, FL 32207

Customer No.: AME400

Quote No.: 33094

Phone 904-737-9292 for Jacksonville Phone 407-859-1515 For Orlando

Quote To: **BEACH COMMUNITY DEVELOPMENT DISTRICT** Ship To: **Amenity Maintenance Group**
 3501 QUADRANGLE BLVD SUITE 270 Division of Vesta Property Services
 ORLANDO, FL 32817 145 Riverside Ave Suite 250
 Jacksonville, FL 32202

Date	Ship Via	F.O.B.	Terms	
11/09/2023		Origin	Net 30	
Quote Description		Sales Person	Quote Expires	
		Clayton Rix	12/09/2023	
Quantity	Item Number	Description	Unit Price	Amount
1		16228CBR30 10W 60 DEG IN GROUND FIXTURE KICHLER	525.00	525.00
40	KT-FLED25PS-C1E-UNV-	8CSB-VIM NON INVENTORY KEYSTONE	92.50	3700.00
			Quote subtotal	4225.00
			Quote total	4225.00
Hope				

Thank You

ESTIMATE



Prepared For

Beach CDD
12788 meritage blvd
Jacksonville , FL 32246
(904) 577-3075

Hubbard Electrical Contracting, LLC

8627 Die Hard Lane
Jacksonville, Florida 32220
Phone: (904) 351-9722
Email: joshhec83@gmail.com

Estimate # 515
Date 01/02/2024
Business / Tax # 88-1086807

Description

change out 40 customer supplied lights
Change out 40 customer supplied landscape lights

Subtotal	\$4,000.00
Total	\$4,000.00

Forms of payment are Check or Cash.

If paying with a Credit Card/PayPal there will be a 4% convenience fee added.

Payment is due upon completion of the job.

By signing this document, the customer agrees to the services and conditions outlined in this document.

C-Series LED

16227, 16228, 16230, 16258

120V-277V LED In-Ground, 10W, 20W



For warranty details visit
Kichler.com/Warranty

PROJECT:

TYPE:

ORDERING:

COMMENTS:

APPLICATIONS

Kichler Lighting's 120-277V LED In-ground Well Lights are available in two beam spreads (45 and 60 degree) and lumen options (775 or 1625) which offer dramatic up-lighting to accentuate architectural details, landmarks and statuary, as well as landscape features.

KEY FEATURE

The fixture features an exterior beam tilt adjustment. Apply an Allen wrench to the designated location at the top of the fixture, just under the trim ring, to adjust the direction of the light (up to 15°). Now you can create striking visual effects without having to open the fixture, which keeps the factory sealed assembly intact to better prevent against water ingress.

CONSTRUCTION

Durable, fully sealed, cast brass housing sits within a heavy-duty polymeric sleeve for direct in-ground or concrete commercial installations. Dual cavity: top protects the optical chamber and LED from heat; bottom further protects potted driver from water ingress. Strain relief at the bottom splice connection is also designed to prevent water ingress. The fixture is built strong to endure the corrosive forces of water, temperature and time.

FINISH

Trim ring in Centennial Brass features a chemically plated base with lacquer finishing (note that brass can patina over time). Stainless Steel trim ring accessory is also available.

INSTALLATION

Composite installation sleeve included for direct in-ground or concrete commercial installations.

LED CHARACTERISTICS

Color-consistent LEDs. Lumen Maintenance: L70 ≥55,000 hours. CRI: 80.

OPTICAL DISTRIBUTION

COB and reflector design offer center-to-edge optics for uniform light distribution. The light emitting portion of fixture is lowered for reduced glare at closer distances.

ELECTRICAL

120V-277VAC (50/60 Hz). Integrated surge protection (4kV) is standard. Driver is fully potted.

LISTINGS AND CERTIFICATION

ETL for Wet Locations. IEC 60598-1. Operating Temperature -40°C to +40°C. IP67 Rated.

ACCESSORY

16290SS – Accessory trim ring in Stainless Steel.

KICHLER

C-Series LED

16227, 16228, 16230, 16258

120V-277V LED In-Ground, 10W, 20W

ORDERING MATRIX (Model # + Finish & CCT Codes) & LUMEN INFORMATION

Model #	Finish	CCT (30 / 40 / 50)	Wattage	Beam	CRI	Lumen	Lm/W	L70 (hrs)
16227	CBR	30 / 40 / 50	9.7W	45°	80+	775	80	≥ 55,000
16228	CBR	30 / 40 / 50	9.7W	60°	80+	775	80	≥ 55,000
16230	CBR	30 / 40 / 50	20.3W	45°	80+	1625	80	≥ 55,000
16258	CBR	30 / 40 / 50	20.3W	60°	80+	1625	80	≥ 55,000

Example: 16230CBR40 is model 16230 (20W, 45°, 1625 LM) in Centennial Brass, 4000K

DIMENSIONS

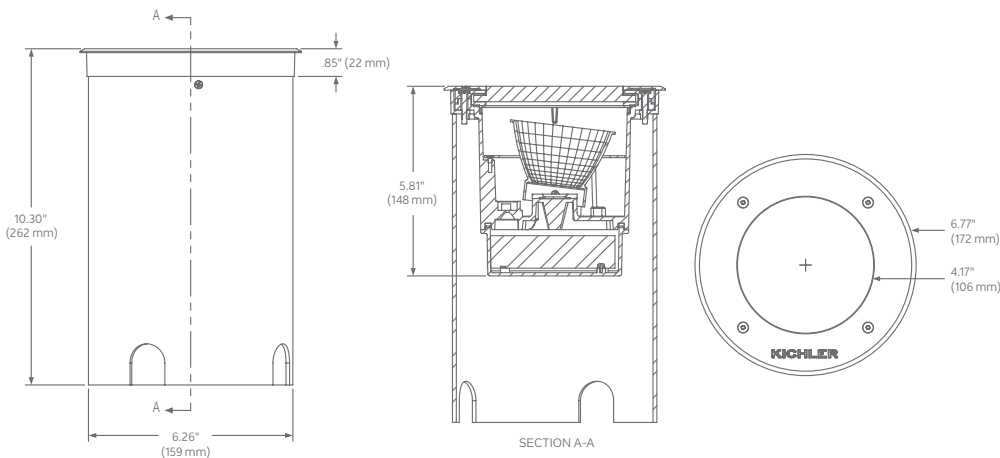

ACCESSORIES

Ordered & shipped separately
16290SS- Stainless Steel
 Trim Ring



BEAM SPREAD AND EXTERNAL BEAM TILT ADJUSTMENT (15° in either direction)

Degree Options

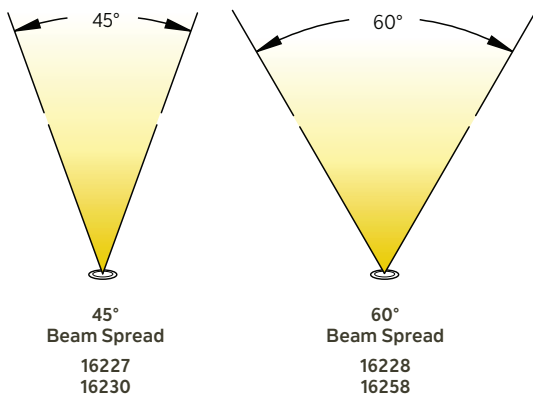

Beam Tilt Adjustment

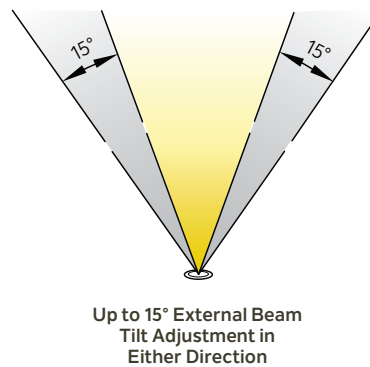

120V-277V LED In-Ground, 10W, 20W

PHOTOMETRIC DIAGRAMS

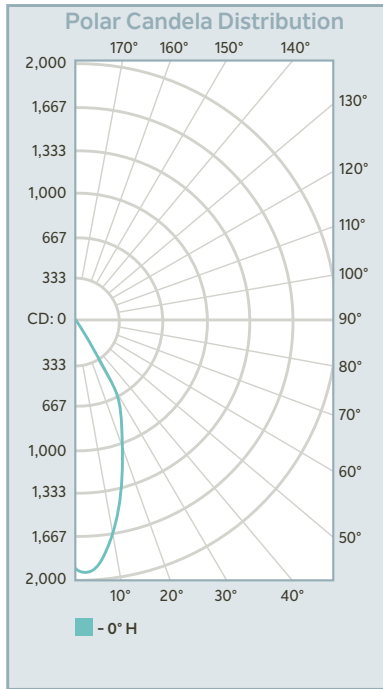

16227

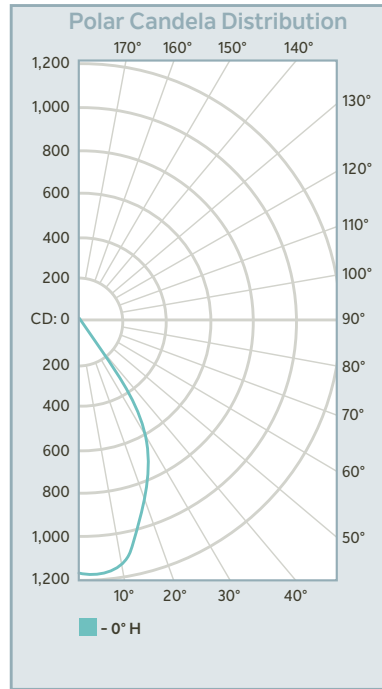

16228

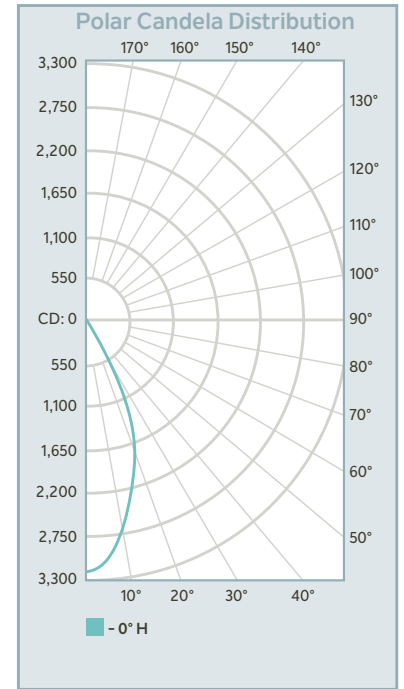

16230

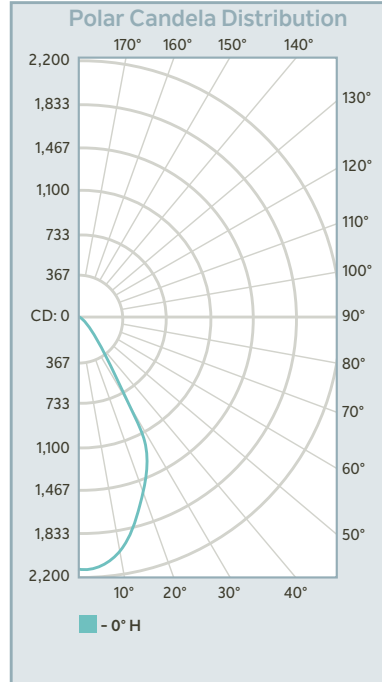

16258

TECHNICAL SUPPORT - Contact Kichler Advanced Product Support: techsupport@kichler.com or 844-KICHLER (844-542-4537) M-F, 8:00 a.m. - 6:30 p.m. ET

FREE LAYOUT DESIGN - Available for Kichler partners - Visit Kichler.com/APS for details.

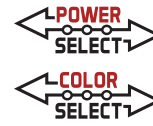

KT-FLED25PS-C1E-UNV-8CSB-VDIM

BULLET FLOODLIGHT

DESCRIPTION

LED Bullet Flood Light with Photocell | Power Select 25/20/15W | Color Select 3000/4000/5000K | 120-277V Input | Bronze Housing



APPLICATION

Perfect in both residential and commercial applications, such as landscape, facade, accent, and flagpole lighting



PRODUCT FEATURES

- Keystone Power Select technology (25/20/15W)
- Keystone Color Select technology (3000/4000/5000K)
- Sturdy, die cast aluminum housing in a sleek, modern design
- NEMA 4H x 4V optics pre installed, with optional NEMA 3H x 3V optics included in box
- IP65 design includes twist on/off lens cap for easy field changeable optics (see instructions for details)
- UL and DLC 5.1 listed
- L70 > 50,000 hours @ 45°C/113°F
- Ambient operating temperature: 40°C/-40°F to 45°C/113°F

PRODUCT SPECIFICATIONS

Catalog Number	Selectable Wattage	Selectable CCT	Lumens	Efficacy	Input Voltage	CRI	Housing Color	Rated Life
KT-FLED25PS-C1E-UNV-8CSB-VDIM	25W	3000K	2971	119 lm/W	120-277V	80	Bronze	50,000 hrs
		4000K	3292	132 lm/W				
		5000K	3273	131 lm/W				
	20W	3000K	2398	120 lm/W				
		4000K	2609	130 lm/W				
		5000K	2580	129 lm/W				
	15W	3000K	1862	124 lm/W				
		4000K	1998	133 lm/W				
		5000K	1986	132 lm/W				

IMAGES

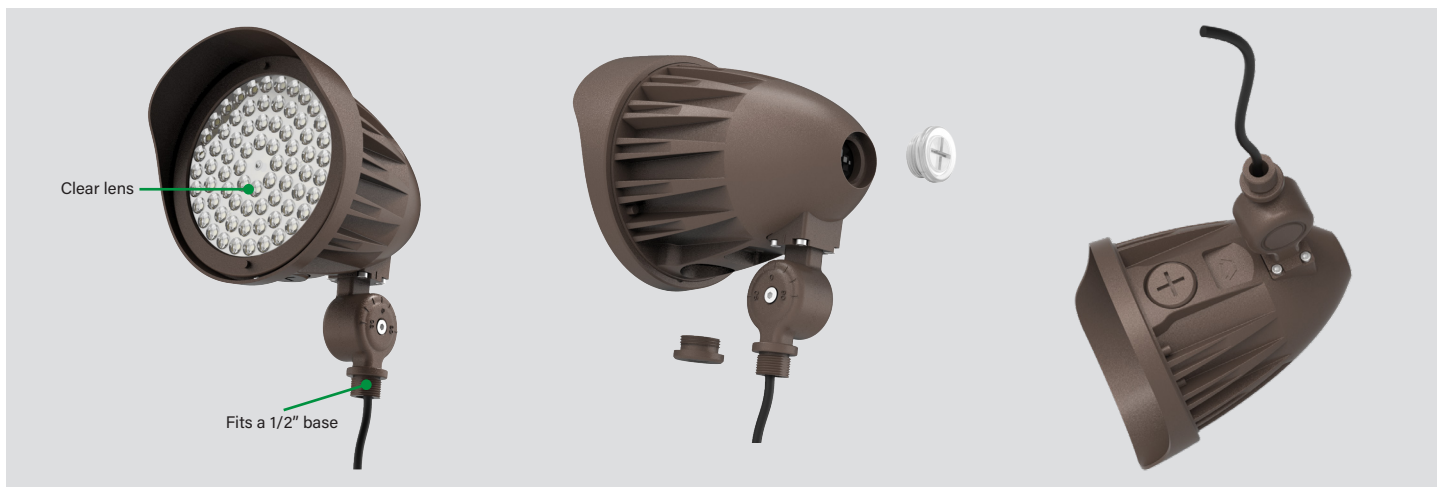

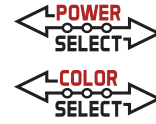

KT-FLED25PS-C1E-UNV-8CSB-VDIM

BULLET FLOODLIGHT

PHOTOMETRICS FOR 4H X 4V LENS AT 25W

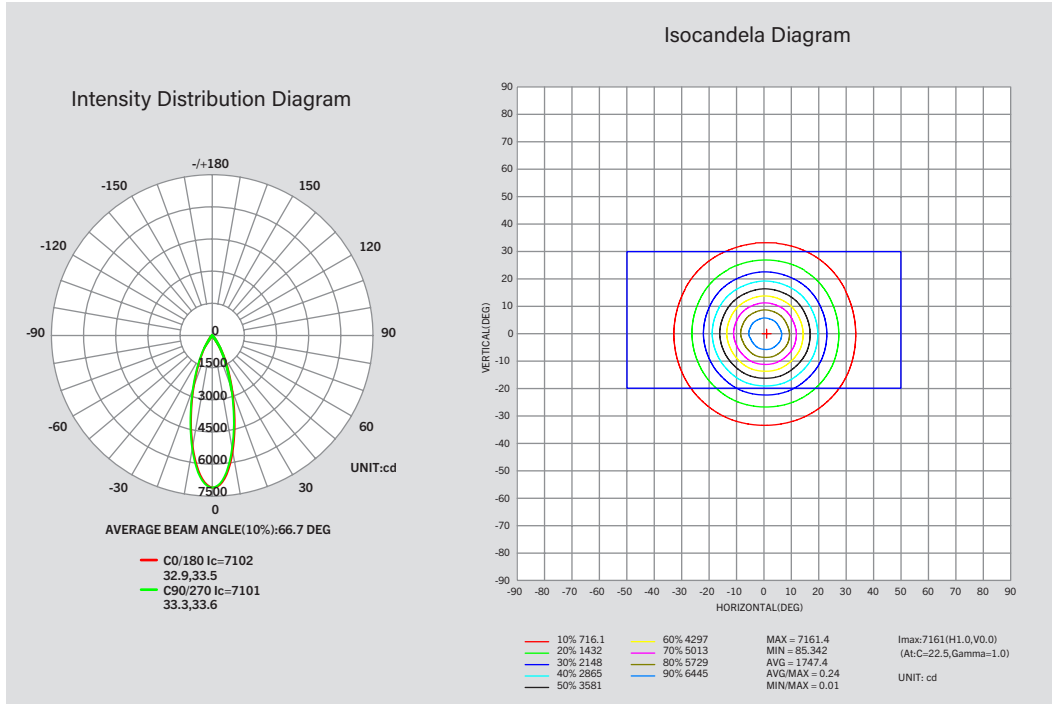

FLUX DISTRIBUTION

Zone	Lumens	% Luminaire
Forward Light	1,638 lm	50.0%
0°-30°	1,241 lm	37.9%
30°-60°	331.76 lm	10.1%
60°-80°	39.975 lm	1.2%
80°-90°	2.9898 lm	0.1%
Back Light	1,635.1 lm	50.0%
0°-30°	1,234 lm	37.7%
30°-60°	323.16 lm	9.9%
60°-80°	50.183 lm	1.5%
80°-90°	4.3756 lm	0.1%
Up Light	45.556 lm	1.4%
90°-100°	1.1682 lm	0.0%
100°-180°	44.388 lm	1.4%

BUG* Rating

Asymmetrical Luminaire Types

Type I, II, III, IV B2 U0 G2

Quadrilateral Symmetrical Luminaire Types

Type V, Area Light B2 U0 G2

* Backlight, Uplight, Glare

PHOTOMETRICS FOR 3H X 3V LENS AT 25W

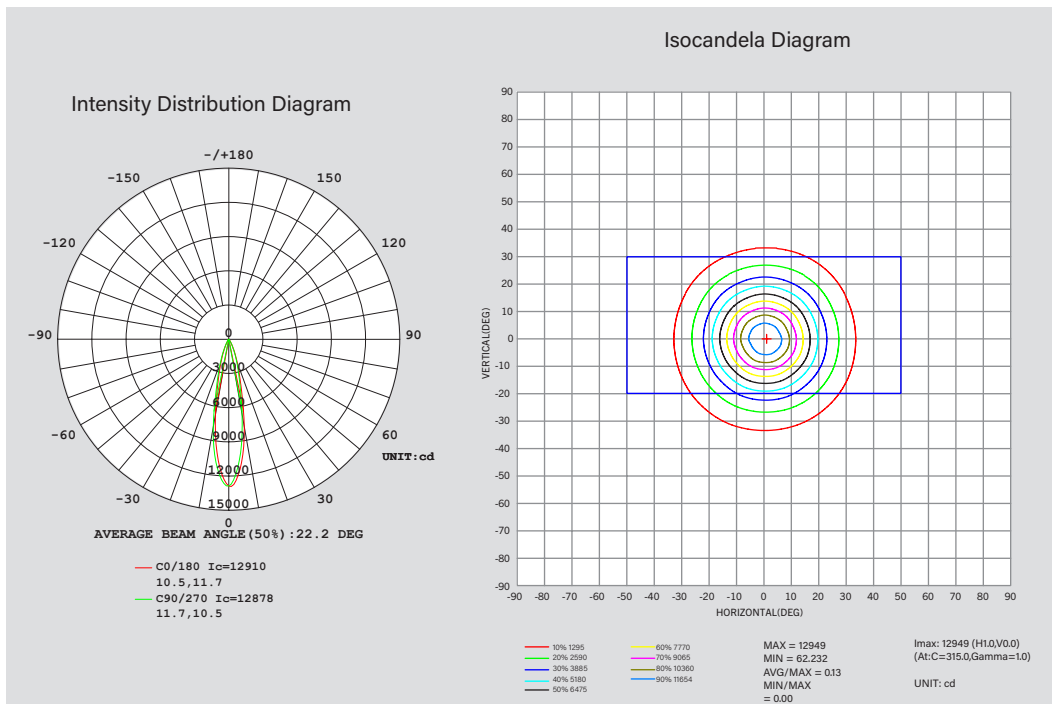

FLUX DISTRIBUTION

Zone	Lumens	% Luminaire
Forward Light	1438.4 lm	48.6%
0°-30°	1,253.6 lm	42.3%
30°-60°	151 lm	5.1%
60°-80°	24.587 lm	0.8%
80°-90°	1.2585 lm	0.0%
Back Light	1522.1 lm	51.4%
0°-30°	1,295 lm	43.7%
30°-60°	155.25 lm	5.2%
60°-80°	55.221 lm	1.9%
80°-90°	8.1574 lm	0.3%
Up Light	16.332 lm	0.6%
90°-100°	0.38046 lm	0.0%
100°-180°	15.952 lm	0.5%

BUG* Rating

Asymmetrical Luminaire Types

Type I, II, III, IV B3-U2-G0

Quadrilateral Symmetrical Luminaire Types

Type V, Area Light B3-U2-G0

* Backlight, Uplight, Glare

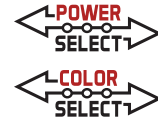

KT-FLED25PS-C1E-UNV-8CSB-VDIM BULLET FLOODLIGHT

LIGHT DISTRIBUTION PATTERN

Aimed 30° below horizontal
10' Mounting Height
3x3 optics

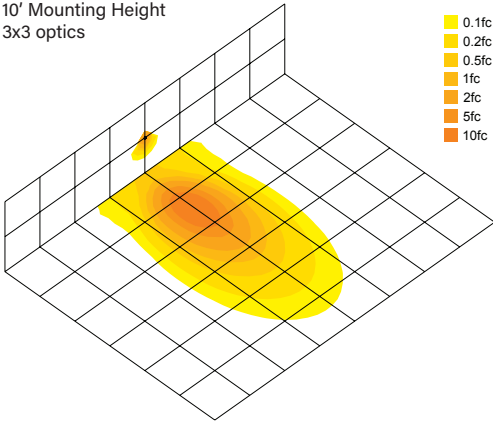

Aimed 30° below horizontal
10' Mounting Height
4x4 optics

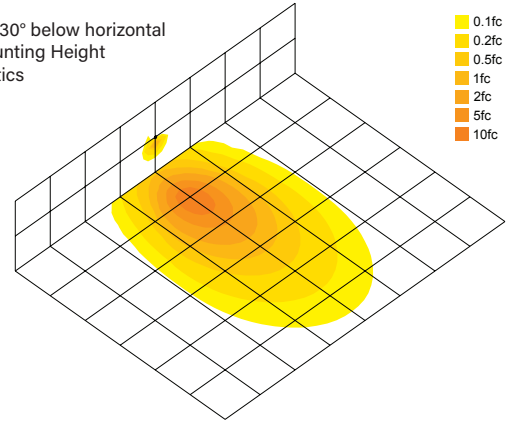

Aimed 45° below horizontal
10' from building
6" above ground
3x3 optics

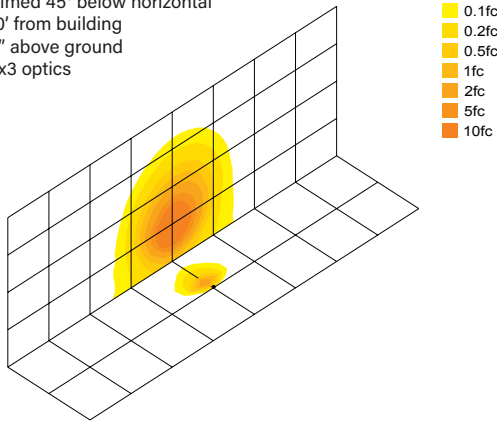

Aimed 45° below horizontal
10' Mounting Height
6" above ground
4x4 optics

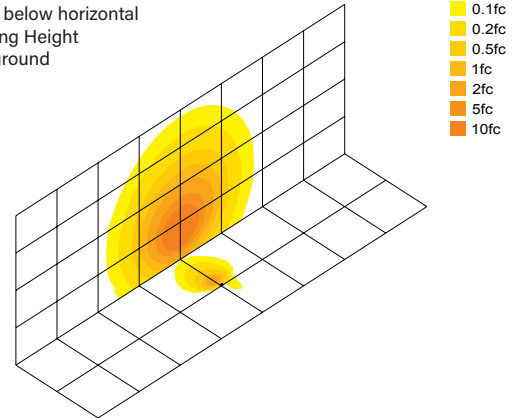

Aimed 60° below horizontal
15' from building
6" above ground
3x3 optics

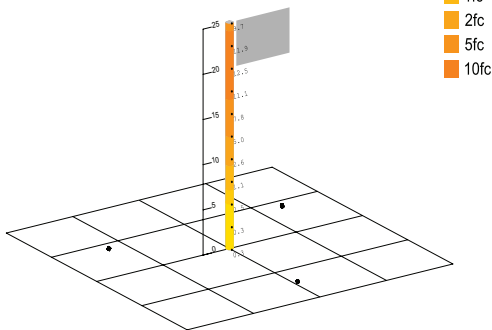

Aimed 60° below horizontal
15' from building
6" above ground
4x4 optics

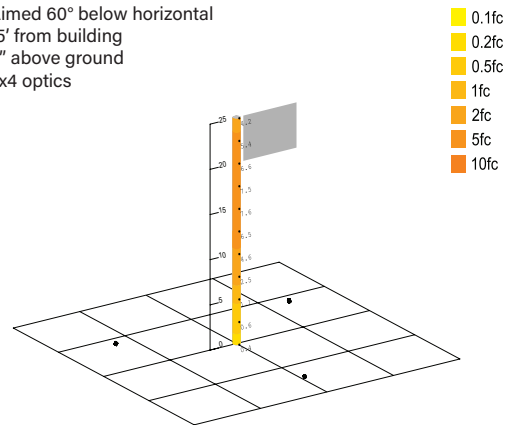

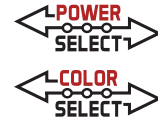

KT-FLED25PS-C1E-UNV-8CSB-VDIM

BULLET FLOODLIGHT

PHYSICAL SPECIFICATIONS

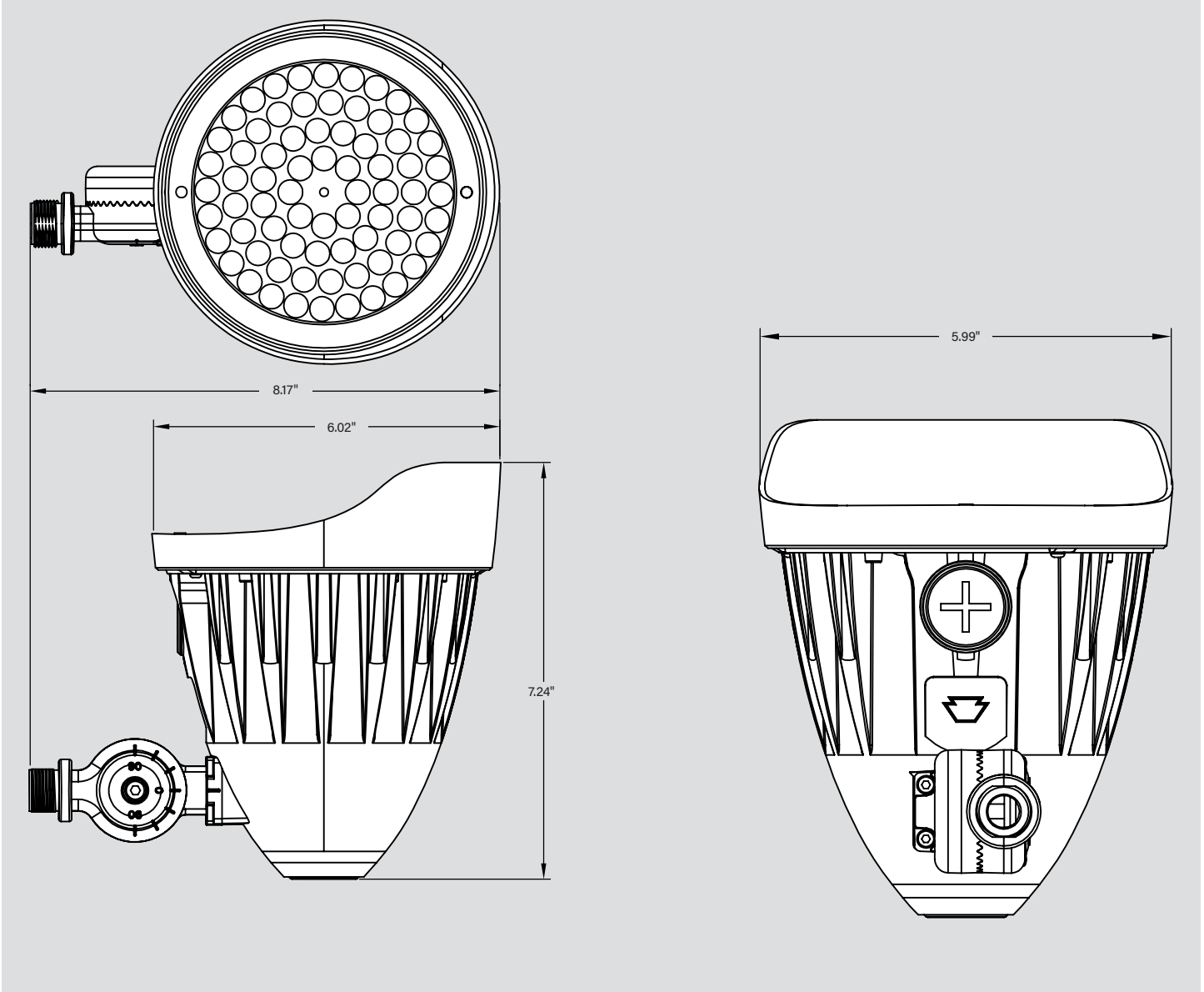

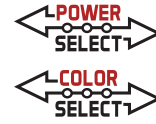

KT-FLED25PS-C1E-UNV-8CSB-VDIM BULLET FLOODLIGHT

POWER SELECT (WATTAGE) AND COLOR SELECT (CCT) ADJUSTMENT

This fixture is equipped with field-adjustable Keystone Power Select and Color Select technology.

1. Ensure power is off to the fixture.
2. Remove knockouts.
3. Adjust dip switches to desired settings.
4. Replace knockouts.
5. Restore power to fixture.

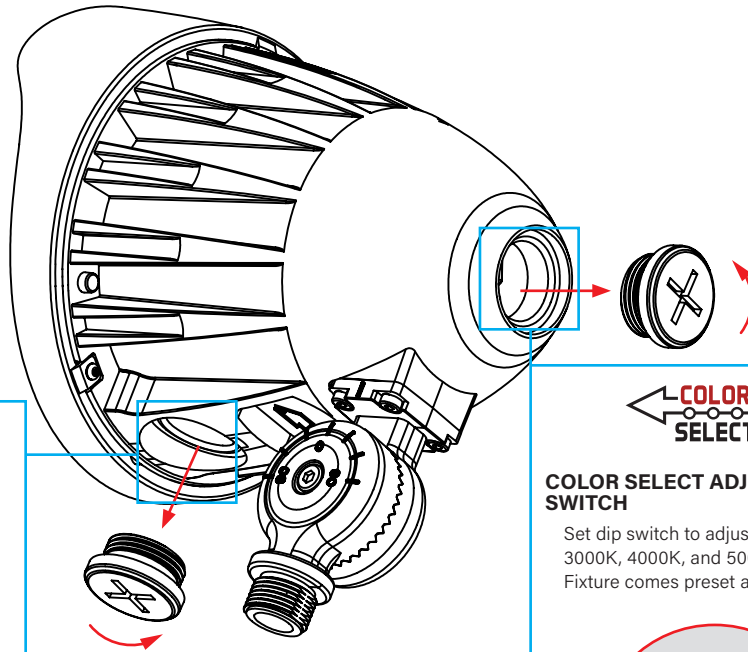

POWER SELECT ADJUSTMENT SWITCH

Set dip switch to adjust wattage between 25W, 20W, and 15W. Fixture comes preset at 25W.

COLOR SELECT ADJUSTMENT SWITCH

Set dip switch to adjust CCT between 3000K, 4000K, and 5000K. Fixture comes preset at 5000K.

PHOTOCELL ON/OFF SWITCH

Set dip switch to turn on or turn off built-in photocell.

KT-FLED25PS-C1E-UNV-8CSB-VDIM

BULLET FLOODLIGHT

LENS REPLACEMENT INSTRUCTIONS

Note: Lens must be changed before installation

1. Take out the 3 reflector screws, and remove reflector from the housing.

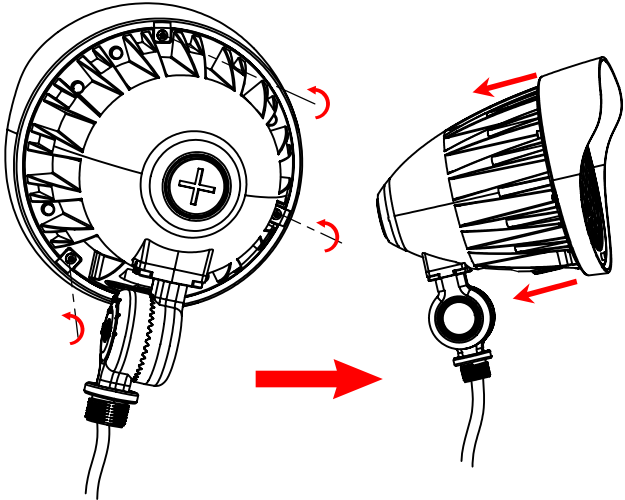

2. Remove the twist on/twist off cap using the wrench tool (provided).

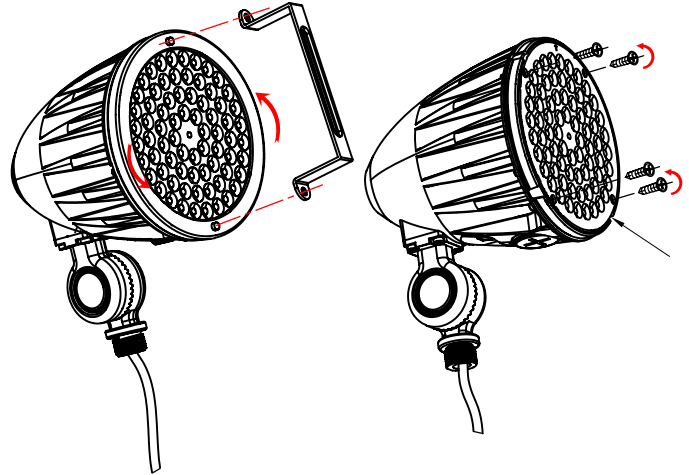

3. Remove screws from the lens and install the NEMA 3H x 3V replacement lens (provided) on the fixture, aligning arrow on lens with arrow on LED board and groove on housing.

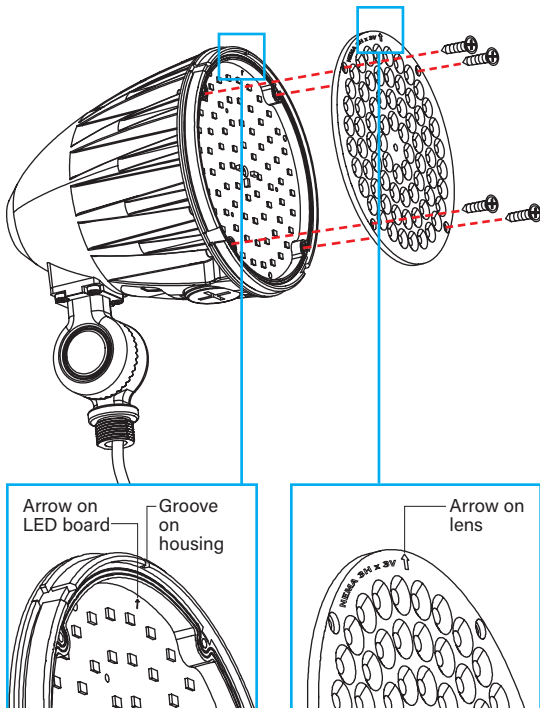

4. Insert and tighten the 4 screws from the lens, twist on the cap, then lock the cap in place with the wrench tool (provided).

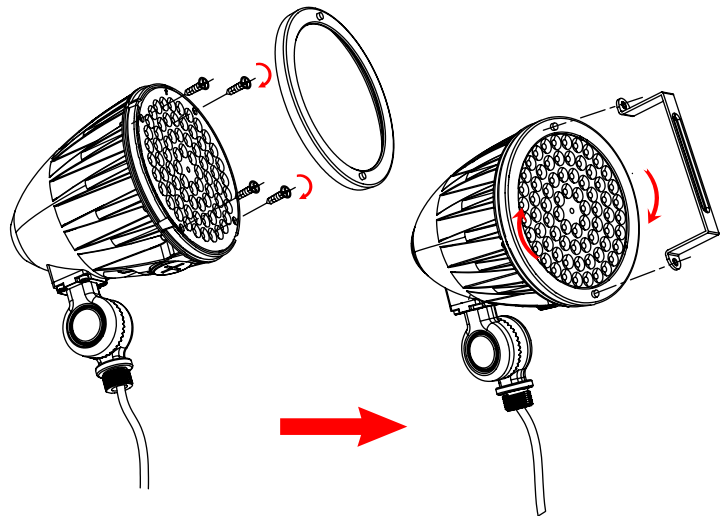

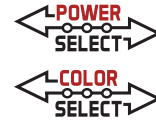

KT-FLED25PS-C1E-UNV-8CSB-VDIM

BULLET FLOODLIGHT

5. Feed the reflector through the back side of the fixture, and tighten the 3 reflector screws.

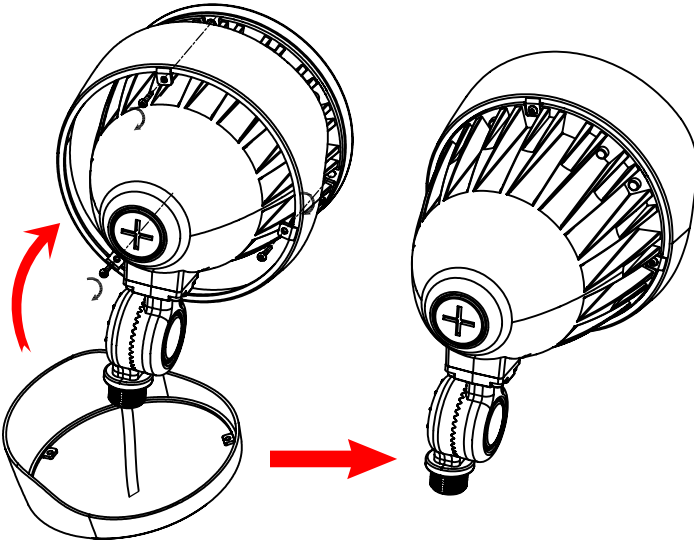

ACCESSORIES

CORD SETS

Factory-Installable OR Field-Installable (field-installable purchased separately)

✓	SUFFIX*	CATALOG NUMBER	DESCRIPTION	UPC	EASY CODE
	/515P6	KT-CS-515P-6-18/3	Cord set; 125V NEMA 5-15P; straight blade plug; 6' SJTOW cable; 18/3 wire	843654140124	UKH-26

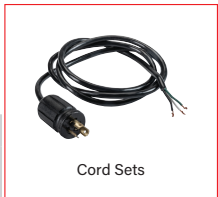

* For factory installation of accessory, add suffix to fixture part number (see ordering examples and instructions on last page of spec sheet).
 Note: For cord sets not listed here, please contact your Keystone sales rep.

ORDERING INFORMATION

ORDER CODE	UPC	EASY CODE	DLC PRODUCT ID
KT-FLED25PS-C1E-UNV-8CSB-VDIM	843654141886	HYH-58	S-NW8ZP1

CATALOG NUMBER BREAKDOWN

KT-FLED25PS-C1E-UNV-8CSB-VDIM

1	2	3	4	5	6	7	8	9	10	11	12
1 Keystone Technologies	2 Floodlight LED	3 Max Wattage	4 Power Select	5 Circular	6 Series 1	7 4H x 4V Distribution	8 Universal Voltage	9 80 CRI	10 Color Select	11 Color Select Designation	12 0-10V Dimming
								11 Color Select Designation			
								B	3000/4000/5000K		

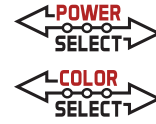

KT-FLED25PS-C1E-UNV-8CSB-VDIM

BULLET FLOODLIGHT

ORDERING EXAMPLES

FIXTURE WITH SINGLE FACTORY-INSTALLED ACCESSORY
KT-FLED25PS-C1E-UNV-8CSB-VDIM /515P6

FIXTURE WITH NO FACTORY-INSTALLED ACCESSORIES
KT-FLED25PS-C1E-UNV-8CSB-VDIM

KEYSTONE FIXTURE	
CATALOG NUMBER	
KT-FLED25PS-C1E-UNV-8CSB-VDIM	

CORD SETS	
SUFFIX	CATALOG NUMBER
✓ /515P6	KT-CS-515P-6-18/3

* When ordering more than one factory-installed accessory, use multiple suffixes as shown in the ordering examples above.
Note: All accessories can also be ordered separately for field installation using just their regular Catalog Number, UPC, or Easy Code.

EXHIBIT 7



Quotation

Quote #: 202149

Date: 01/05/2024

Billed To: Vesta Property Service
200 Business Park Circle #101
St. Augustine FL 32095

Project: 32253
Beach CDD Enhancements
200 Business Park Circle #101

St. Augustine FL 32095

This quote is valid until: 02/04/2024

Description	Common Name	Quantity
Landscape Enhancement on Meritage Blvd		
(4) Pallets of Empire Zoysia		1.00
Demo / Prep		1.00
Notes		
	Total:	\$2,160.00

Approved: _____

Date: _____

5000-18 Highway 17 No. 235 Fleming Island, FL 32003 Office: (904) 778-1030 Fax: (904) 778-1045

Email: cryan@treeamigosoutdoor.com
website: www.TreeAmigosOutdoor.com



Quotation

Quote #: 202151

Date: 01/05/2024

Billed To: Vesta Property Service
200 Business Park Circle #101
St. Augustine FL 32095

Project: 32253
Beach CDD Enhancements
200 Business Park Circle #101

St. Augustine FL 32095

This quote is valid until: 02/04/2024

Description	Common Name	Quantity
Landscape Enhancement on Meritage Blvd		
(70) Fashion Azalea		1.00
(6) Bales of Pine Straw		1.00
Demo / Prep		1.00

Notes

Total: **\$1,865.00**

Approved: _____

Date: _____

5000-18 Highway 17 No. 235 Fleming Island, FL 32003 Office: (904) 778-1030 Fax: (904) 778-1045

Email: cryan@treeamigosoutdoor.com
website: www.TreeAmigosOutdoor.com

EXHIBIT 8

Date of Action Item	Action Item	Status
	Field Operations Manager Section	
4/17/2023	FOM to visit Durbin Crossing regarding pool lanes	Scheduled for 12-14-23. Visit made but pool is undergoing repairs.
7/17/2023	FOM to obtain quotes for beam over visitors entrance lane at guard house	Underway—FOM is going to obtain quote for vendor to install.
7/17/2023	FOM to obtain quote for shade on playground.	Underway. Initial quote provided at 9/18 meeting. Guidance provided to staff regarding future quotes including drawings; also provide financing information when doing budget for FY 2025
10/16/2023	FOM to obtain quotes for pool lighting replacement	On 1/15/2024 Agenda
10/16/2023	FOM to obtain quotes for Tamaya Blvd. lighting and pictures of areas covered by quotes	Pictures emailed to Board on 1/5/2024. Ron will estimate replacement cost based on pool light quotes and discuss with Board on 1/15/2024.
11/20/2023	FOM to get quote for portable pressure washing machine	FOM located a sidewalk cleaning disk that will work with existing equipment. This item is no longer needed.
11/20/2023	FOM to establish schedule to pressure wash assets of the District	Underway—on site meeting with vendor scheduled for 1/12/2024
11/20/2023	FOM to obtain proposal to remove ornamental grasses from intersection of Cassia and Meritage and to replace with sod	On 1/15/2024 Agenda
11/20/2023	FOM to obtain quotes for trimming trees on CDD property in front of homes whose branches are blocking the use of sidewalks	Underway
11/20/2023	FOM to look into a scanner for QR Codes and ability for clickers/transponders for use of resident's side of entry gate	Underway

12/18/2023	FOM to Obtain Proposal (for Chair to Sign) that would Employ an Arborist to provide Report with Respect to Identify Which Trees to Keep and What to Do with Ones that are Kept, what to plant for those removed (NTE \$5K)	Underway
12/18/2023	FOM to arrange to have tree stakes removed from around amenity center (NTE \$1,500)	Underway
12/18/2023	FOM to obtain proposals consistent with Supervisor Korsakova's irrigation handout (4 recommendations)	Underway
12/18/2023	FOM and AM to work with Dr. Renn on format for fitness room usage data to be included on AM monthly report	Underway
12/18/2023	FOM to send DM pictures of landscape lighting on Tamaya Boulevard to be forwarded to Board members	Done
	Amenity Manger Section	
10/16/2023	AM to research if CPR classes can be conducted for residents	Underway
10/16/2023	AM to obtain quotes for Summer Camp	Underway
11/20/2023	AM to send out E-Blast with new operating hours after New Year	
11/20/2023	AM to hold workshop on event ideas (approximately every 6 months)	Scheduled for January 9 th , 2024
12/18/2023	AM and FOM to work with Dr. Renn on format for fitness room usage data to be included on AM monthly report	Underway
12/18/2023	AM to send out E-Blast on use of gates. To work with Brittany Bell on language of E-Blast	

	District Manager Section	
9/18/2023	DM to seek reimbursement from ICI for tree removed near basketball court	Underway 11/15: Invoice sent
10/16/2023	DM to send out approved letter to commercial property owners along Tamaya Boulevard (send UPS Tracking). Amend letter to include language provided by Dr. Renn	Underway 10/20: Letter sent; 10/27 and 11/15: follow ups made
11/20/2023	DM to contact vendors and request that they submit what they recommend a scorecard to look like with respect to their services	Scorecards received from Vesta Property Services and Advanced Security. Ready for Board to consider at a workshop.
12/18/2023	DM to write letter to resident whom Advanced Security complained about requesting he appear at a meeting to address the Board regarding reason why he does not want to provide identification at guard gate	12/22: Done
12/18/2023	DM to add November incident to Incident Report section of monthly report	12/19: Email to Dana and Oliver asking for this to be added
	District Engineer Section	
	District Counsel Section	
11/20/2023	DC to review Tree Amigos merger and see if changes are necessary to the Landscape Maintenance contract	
12/18/2023	DC to draft demand letter to developer to remove all trees on CDD property and to replace with sod. To bring back before the Board for review and approval.	
	Board of Supervisors Section	
12/18/2023	Dr. Renn to work with FOM and AM on format for fitness room usage data to be included on AM monthly report	Underway

EXHIBIT 9

BEACH CDD MEETING AGENDA MATRIX

January, 2024	Regular Meeting: 1/15	<p>Vendor Reports</p> <ul style="list-style-type: none"> • LLS Tax Solutions, Inc—Arbitrage Report for Period Ending 11-3-2023 <p>Presentations</p> <p>Consent Agenda Items</p> <ul style="list-style-type: none"> • Meeting Minutes--12/18/2023 Regular Meeting • Unaudited Financials--December 2023 <p>Business Items</p> <ul style="list-style-type: none"> • Consideration of Proposal(s) for landscape lighting on Tamaya Boulevard • Consideration of Resolution Amending the FY 2023 budget <p>Discussions</p> <ul style="list-style-type: none"> • Board discussion with Trustee • Board discussion with Resident About Showing ID at Guard House <p>Closed Session</p> <ul style="list-style-type: none"> • Discussion on Security Related Issues <p>Staff Reports</p> <ul style="list-style-type: none"> • District Manager <ul style="list-style-type: none"> ○ Resident(s) Subject to Disciplinary Action ○ Incident Report Tracker ○ Action Item Report ○ Meeting Matrix ○ Workshop date, time and topics ○ FY 2025 Draft Budget Presented • District Counsel 	<ul style="list-style-type: none"> • Ed Edmiston to provide information as to monies invested
----------------------	----------------------------------	---	--

BEACH CDD MEETING AGENDA MATRIX

		<ul style="list-style-type: none">○ Draft Demand Letter Regarding Trees Planted on CDD Right-of-Way● District Engineer	
--	--	---	--

BEACH CDD MEETING AGENDA MATRIX

<p><i>February, 2024</i></p>	<p><i>Regular Meeting: 2/19</i></p>	<p><i>Vendor Reports</i></p> <p><i>Presentations</i></p> <p><i>Consent Agenda Items</i></p> <ul style="list-style-type: none">• Meeting Minutes--1/15/2024 Regular Meeting• Unaudited Financials--January 2024 <p><i>Business Items</i></p> <p><i>Discussions</i></p> <ul style="list-style-type: none">• FY 2025 Draft Budget--continued <p><i>Staff Reports</i></p> <ul style="list-style-type: none">• District Manager<ul style="list-style-type: none">○ Resident(s) Subject to Disciplinary Action○ Incident Report Tracker○ Action Item Report○ Meeting Matrix• District Counsel• District Engineer	
------------------------------	---	--	--

BEACH CDD MEETING AGENDA MATRIX

<p><i>March, 2024</i></p>	<p><i>Regular Meeting: 3/18</i></p>	<p><i>Vendor Reports</i></p> <p><i>Presentations</i></p> <p><i>Consent Agenda Items</i></p> <ul style="list-style-type: none">• Meeting Minutes—2/19/2024 Regular Meeting• Unaudited Financials—February 2024 <p><i>Business Items</i></p> <p><i>Discussions</i></p> <p><i>Staff Reports</i></p> <ul style="list-style-type: none">• District Manager<ul style="list-style-type: none">○ Resident(s) Subject to Disciplinary Action○ Incident Report Tracker○ Action Item Report○ Meeting Matrix• District Counsel• District Engineer	
---------------------------	---	---	--

BEACH CDD MEETING AGENDA MATRIX

<i>Unscheduled Items</i>	<p><i>Presentations</i></p> <ul style="list-style-type: none"> • Bank account presentation by Skye Lee <p><i>Consent Agenda Items</i></p> <p><i>Business Items</i></p> <p><i>Discussions (Workshop)</i></p> <ul style="list-style-type: none"> • CDD Agreement to allow HOA to enforce no parking on CDD owned streets • Trees/Tree Damage • Overnight Parking on Roadway—Make this a violation of Amenity Policies • Vendor Scorecards • Advanced Security Issues • Additional Testing of Pool Water • Discipline Process • Agreement with City of Jacksonville for off-duty patrol of police • Post Orders <p><i>Staff Reports</i></p> <p><i>Public Hearing</i></p> <p><i>Vendor Reports</i></p> <ul style="list-style-type: none"> • Second speed study conducted by Jake 		<ul style="list-style-type: none"> • Could be done during a workshop • 2/7: Reply from HOA • From 11/20 meeting • Based on issue of indemnification, the Board tabled this matter on 7/17/2023. • Supervisor Korsakova has requested receiving the raw data
--------------------------	--	--	--

BEACH CDD MEETING AGENDA MATRIX

SUBJECT	NOTES
Safety and Security	<ul style="list-style-type: none">• Speeding in Community• Single Point of Entry/Sign-In Point for Amenities• Point of Entry for Sidewalks
Expanding Amenities	<ul style="list-style-type: none">• Facilitators
Pocket Parks	<ul style="list-style-type: none">• Beautification

BEACH CDD MEETING AGENDA MATRIX

MAJOR CONTRACT VENDOR NAME/SERVICE	EXPIRATION DATE/COMMENTS
Amenity Management/Vesta Property Services	12/13/2021-9/30/2025 (District 60 days without cause; Contractor has 90 days). First Amendment was effective on 2/7/2022.
Aquatic Management/Lake Doctors	10/1/202-9/30/2024 (30 days)
Arbitrage Services/LLS Tax Solutions	Period ending 11/3/2023
Audit Services/DMHB	Fiscal Year ending 9/30/2024
Cintas/AED Lease-Purchase	Ending 11/2026
Criminal Background Checks/Screening One	3/15/2023-1 year auto renewal
District Counsel Services/Kutak Rock LLP	12/27/2022-
District Engineer Services/England-Thims & Miller, Inc.	9/18/2023-9/30/2024
District Management Services/DPFG (d/b/a Vesta District Services)	5/1/2022- 9/30/2023-1 year auto renewal
Fire Alarm Monitoring & Inspection/Wayne Automatic Fire Sprinklers, Inc.	10/1/2022-10/1/2023-auto renews for 1 year twice (60 days for failure to perform; 30 days without cause)
Janitorial Services—Jani-King Inc	9/27/2023-9/30/2024 – 1 year auto renewal 5 times (30 days)
Landscape Maintenance/Tree Amigos Outdoor Services, Inc.	7/1/2023-6/30/2026 (60 days for failure to perform; 30 days without cause)
Pest Control/Turner Pest Control	3/23/2017-
Security Guard Service/Advanced Security Specialist & Consulting LLC	1/21/2021- (District and Contractor 30 days without cause); First Amendment was effective on 9/28/2021; Second Amendment was effective on 10/13/2022; Third Amendment was effective on 3/5/2023
Towing Service/ASAP Towing and Storage	12/6/2022-
Website Hosting/Campus Suite	4/1/2022-9/30/2022; 1 year auto renewal